

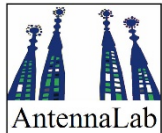

## Antennas and Wireless Systems Lab Call for Applications

Coordinators: Profs. L. Jofre, J. Romeu  
Department of Signal and Communications  
Telecom Engineering School  
Universitat Politècnica de Catalunya



---

**Antennas and Wireless Systems Lab:**

L. Jofre, J. Romeu, J.M. Rius, A. Elias, S. Blanch, M.C. Santos



# 2016-17 Research Internship Call



- The goal of the internship is to initiate graduated students into the research in the field of “advanced electromagnetic radiation, antennas and wireless systems”
- The work will consist on studies either analytical, numerical or experimental and an initial part of the work may be performed over existing software packages (Matlab, CST, HFSS, COMSOL, etc.). A personal support will be given by the professors of the Research Lab.
- The students will participate into the ongoing studies and group research projects and will get used to the different tools (both numerical and experimental used into the Lab), and in same case they may be associated to some research publication paper.
- The Internship will be associated to: a) an Introductory Research Program (**IRP**) compatible with a regular academic program (up to 10h/week), or b) the completion of an academic Final Project Work (**FPW**) either at “Graduado” or Master level.
- The Internship could be associated to a grant with an equivalent monthly stipend of around 250€/month, and eventually could get academic credit recognition.
- The Program will operate in an open way during the academic year 2016-17 and different calls, basically for the two academic semesters will be announced. The duration of the Internship may be 6-9 months starting mid-September 2016.
- Please contact Prof. Lluís Jofre ([jofre@tsc.upc.edu](mailto:jofre@tsc.upc.edu)) for additional information.
- Students from previous years having completed the Internship Program are nowadays distributed through the world as researchers, university professors or industry and corporate consultancy companies leading positions.

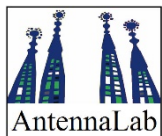

## Antennas and Wireless Systems Lab:

L. Jofre, J. Romeu, J.M. Rius, A. Elias, S. Blanch, M.C. Santos



# AntennaLab Research Internship Application Process



- Send a email to [jofre@tsc.upc.edu](mailto:jofre@tsc.upc.edu) before (first assignment will be done by July 15<sup>th</sup> and a second one on September 30<sup>th</sup>, 2016) with the following basic information:
    - Full name
    - Actual academic situation (degree and year you have completed during 2015-16 and the planned situation for 2016-17)
    - Intended Program either **IRP** or **FPW**
    - Field of interest (you may choose more than one) among the different proposed subjects (eventually propose another related field)
    - Your basic interest (analytical, numerical, experimental)
    - Your general average qualifications (both global and specific into the related fields)
    - Period of interest (6 to 9 months)
    - Your mid and long term interests and motivations (staying into the research, mowing internationally, etc.)
- 

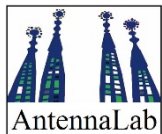

## Antennas and Wireless Systems Lab:

L. Jofre, J. Romeu, J.M. Rius, A. Elias, S. Blanch, M.C. Santos

*The connected car, as a convergence of the automotive, software and telecom industry, opens a bunch of new opportunities and challenges (mobility management, infotainment, communications, sensing) both from the research and industrial scopes.*

## An emerging Communication and Sensing Platform

- Vehicle-to-vehicle (v2v) interactions
- Vehicle-to-infrastructure (v2i) interaction
- Vehicle-to-device (v2d) interaction

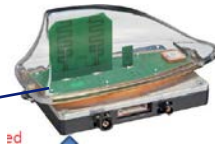
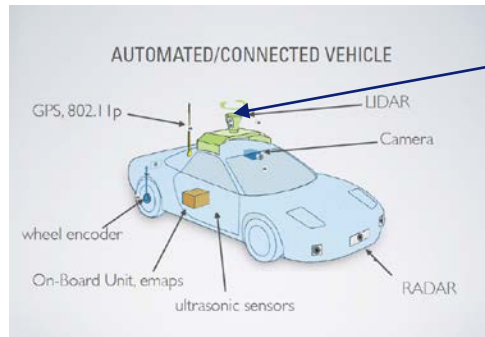

## Research topics

- Wireless Network system architectures
- SNR budgets for the different systems
- In and out of the car propagation modeling

H. Lind, "How new Active Safety Systems and Always Connected Vehicles leads to Challenges on Antenna Design and Integration in the Automotive Domain", 7<sup>th</sup> Eu Conf on Antennas and Propagation, EuCAP 2013

*The unstoppable evolution of the wireless communication devices towards miniaturization enforces the use of very small integrated antennas*

## Next generation Wireless Sensors

- Miniature wireless systems
- Tiny 5G antennas everywhere
- Miniaturization and integration
- Low Power, Low Cost
- UWB Sensing

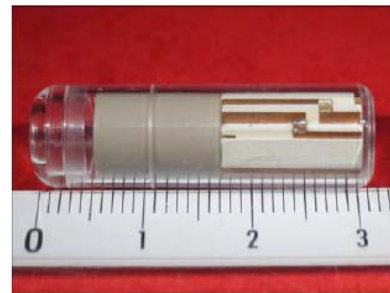
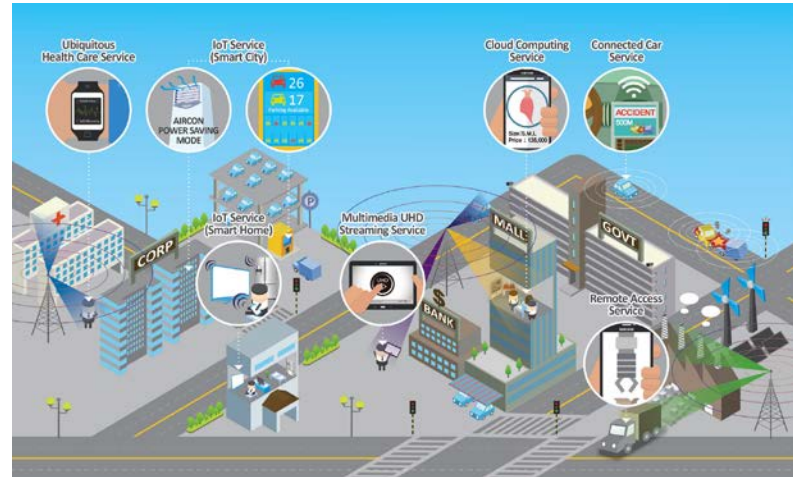

EPFL

## Research topics

- Small antenna design and manufacturing
- Active Antenna
- Integration technologies

B. Costa, "Optimizing Antenna Design for 5G and the Internet of Things", COMSOL blog, June 2015

"5 Antenna Topologies Squeeze into IoT Modules, Microwaves & RF, Feb. 9, 2015

*With the increasing demand for higher data rates, MIMO systems are attracting much attention. Coming massive (large-scale) multi-user MIMO systems opens new opportunities to improve system capacity and energy efficiency.*

## Massive MIMO system capacity and efficiency

- Microwave and millimeter-wave MIMO propagation
- Massive MIMO vs. beamforming
- Antenna and channel correlation

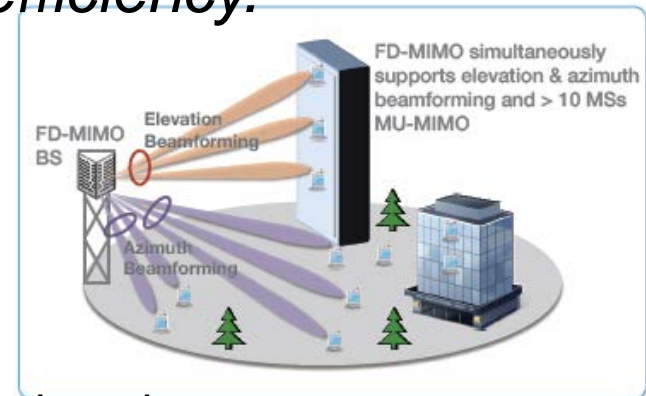
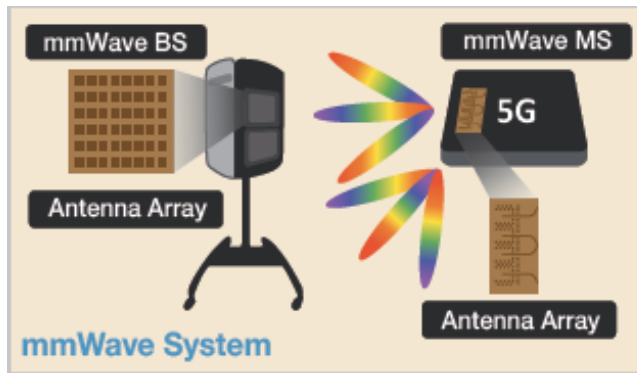

## Research topics

- Channel Modeling
- Matching-Decoupling Circuits
- Mobile Radio Channel Modeling
- Space-Time Coding

A. Gupta, et al., "A Surevey of 5G Network: Architecture and Emerging Technologies", IEEE Acces, July 2015



*The 5G network is coming to mobile broadband and using the spectrum in a disruptive way. The antenna will be a critical element of this new system architecture*

## 5G Smart Antenna Technologies

- 5G Cellular System
- Role of Smart Antennas

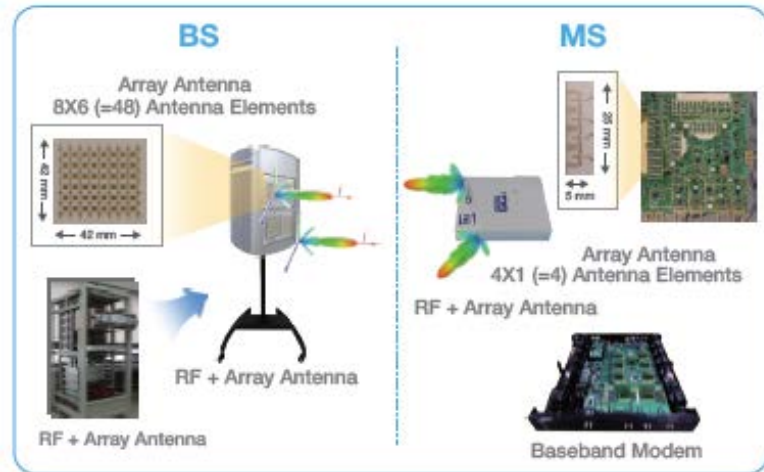
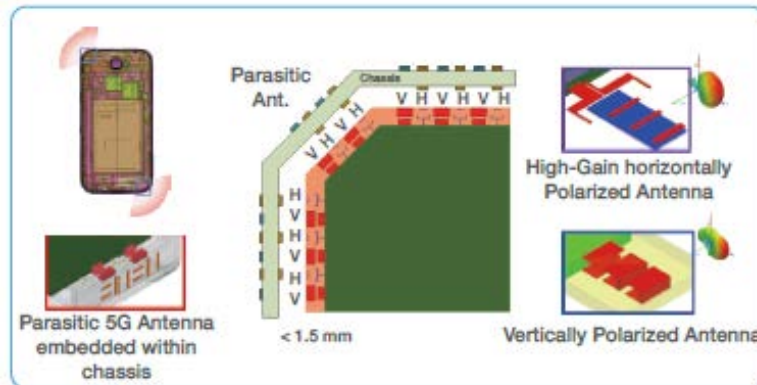

## Research topics

- 5G Smart antenna architectures
- Multi-modal (communication and sensing) architectures
- Multibeam-multiservice

[https://www.google.es/search?q=5G+antenna+for+communiactions+and+radar&ie=utf-8&oe=utf-8&client=firefox-b&gfe\\_rd=cr&ei=m3ZiV\\_HbFqKp8wfjqqOoBQ#q=5g+antenna+requirements](https://www.google.es/search?q=5G+antenna+for+communiactions+and+radar&ie=utf-8&oe=utf-8&client=firefox-b&gfe_rd=cr&ei=m3ZiV_HbFqKp8wfjqqOoBQ#q=5g+antenna+requirements)

*Next generation of communication systems require capacities and reconfigurability that THz with an appropriate photonic processing may provide.*

## THz-Photonics for femtosecond electronics

- THz propagation parameters
- Photonic vs. electronics
- Photomixing modeling

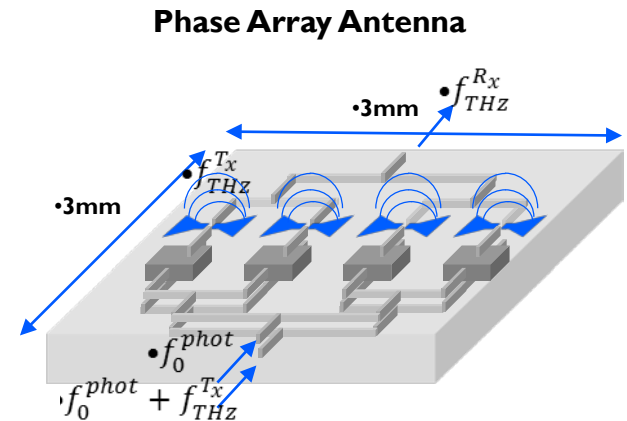
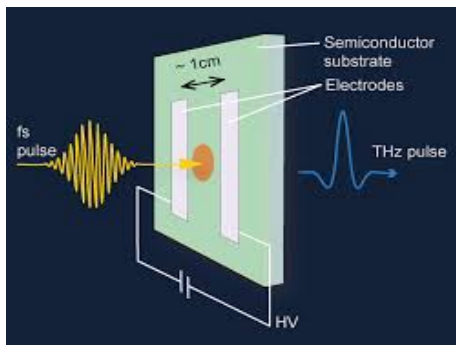

## Research topics

- Photoconductive material electronics
- Very large band self-complementary antennas
- Frequency and time domain operation
- Multilayer antenna design.

N. Burford, et al., "Computational modeling of plasmonic thin-film terahertz photoconductive antennas", Journal of the Optical Society of America, vol. 33, no. 4, April 2016, pp. 748-759



Millimeter-wave mobile communication offers extremely wide frequency bands and compact-size antennas making them very attractive for a new generation of indoor and outdoor high-rate radio-links.

## Millimeter-wave communication systems

- High-rate radio links
- Multi-beam wireless systems
- Millimeter-wave integration technologies
- Radio-spectrum usage and energy efficiency

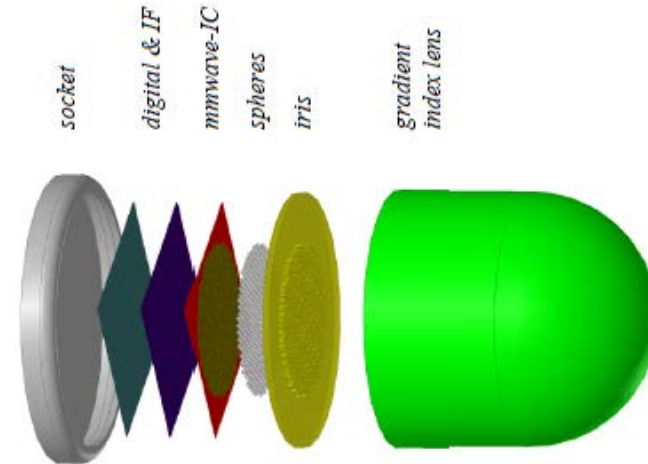
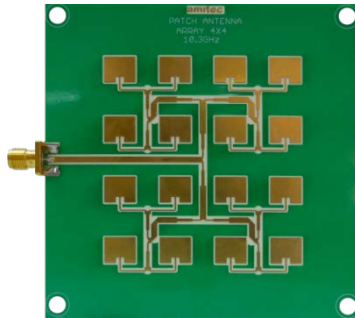

## Research topics

- Multi-layer patch antennas
- Phased-array design
- Inter-element mutual-coupling
- Radiation coverage and polarization

H.K. Pan, et al., "Mm-wave Phased Array Antenna Integration on Semi-Flex Packaging", IEEE Int. Symp. Antennas and Propagation (APSURSI), 2011

*Safety is one of the central concerns for coming automotive driving. 79 GHz UWB automotive radars allow improved resolution and wide-angle monitoring.*

## Next generation of automotive radars

- Safe and autonomous driving performances
- Ultra-wide band FMCW radars
- Antenna technologies

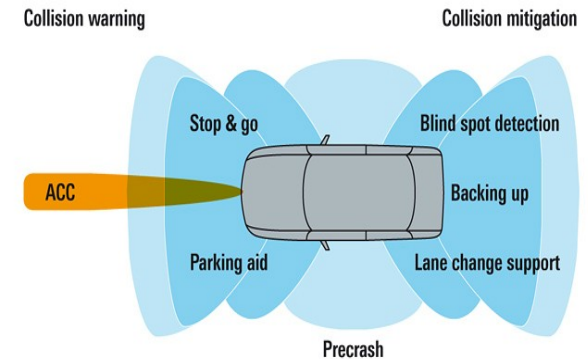
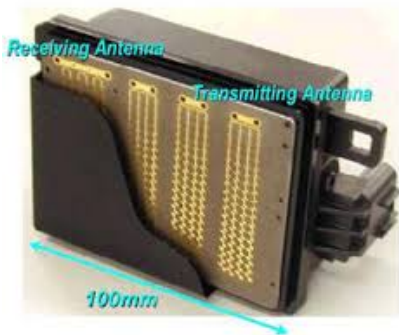

## Research Topics

- Radar detection areas and antenna specifications
- Spatial resolution and Direction of Arrival estimation
- Multi-beam antenna design

F. Bauer, et al., "A 79-GHz Radar Sensor in LTCC Technology Using Grid Array Antennas", IEEE Trans. Microwave Theory and Techniques, vol. 61, n0. 6, June 2013, pp.2514-2521

*Microwaves offer the possibility to monitor the brain functionality using a portable safe and well fitted system*

## Next generation of microwave imaging

- Miniature microwave sensors
- Wireless operation
- Low Power, Low Cost
- 1- 3 GHz UWB Sensing

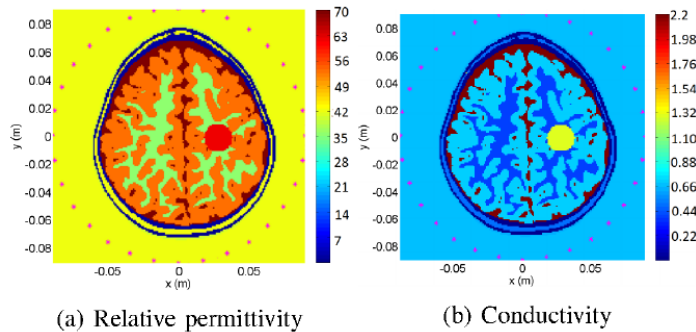

## Research topics

- Brain electrical behavior
- Microwave wireless sensors
- Electromagnetic imaging algorithms
- Portable imaging system design

M. Guardiola, et al., "3D UWB Magnitude-Combined Tomographic Imaging for Biomedical applications. Algorithm Validation", Radioengineering, Vol. 20, no. 2, pp. 366-372

*Microwaves offer the possibility to discriminate between benign and malignant tissues giving the possibility to significantly improve the diagnostic process using light wireless sensing.*

## Next generation of microwave imaging

- Miniature microwave sensors
- Wireless operation
- Low Power, Low Cost
- 8-12 GHz UWB Sensing

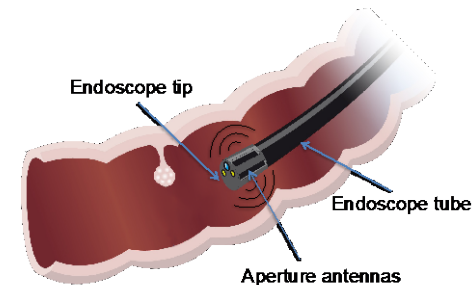
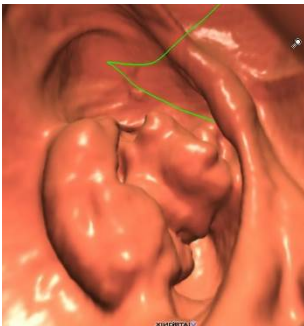

## Research topics

- Colon physiology electromagnetic parametrization
- Microwave reflective sensors
- Short-range radar algorithms
- Endoscopic imaging system design

Z. Wang, et al., "Medical applications of Microwave Imaging", The Scientific World Journal, October 2014

*Terahertz waves unique capabilities in terms of penetration-resolution compromise offer new possibilities to look at the superficial cancer early detection.*

- Terawaves as a new imaging modality
- Photoconductive wireless transceivers
- Physiological behavior of benign and malignant tissues
- 1-2 THz THz UWB Sensing

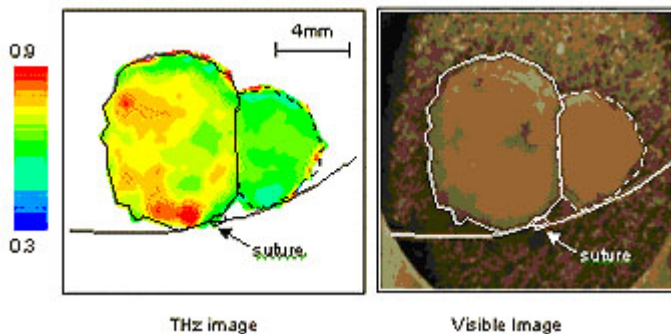
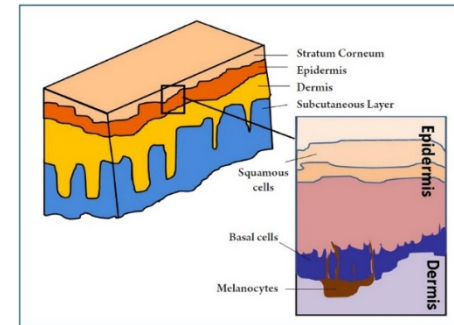

## Research topics

- Tissue THz electromagnetic parametrization
- THz transceiver design
- Terahertz Microwave Reflective Imaging
- Short-range radar algorithms
- THz Portable imaging system design

E. Pickwell, et al., "Terahertz Imaging and Spectroscopy of Skin Cancer", Biological and Medical Applications, Int. Conf. on THz Electronics, 2004



*Near-field microwave microscopy uses the spatially highly concentrated field produced by miniature probe tips to obtain sub-wavelength resolution images that goes orders of magnitude further than the diffraction limit.*

## Near-field sensing

- Near-field propagation and diffraction
- Material microscopic topographic characterization
- Frequency, proximity and resolution compromise

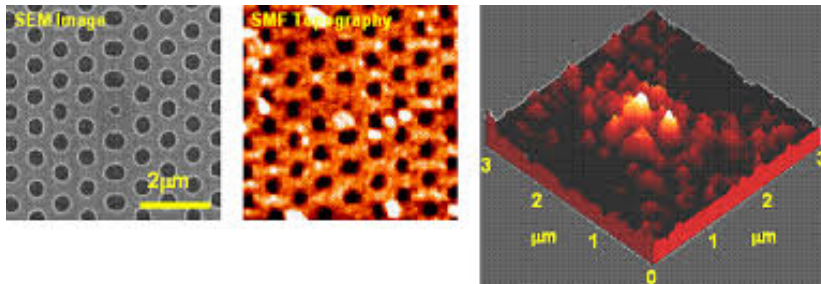
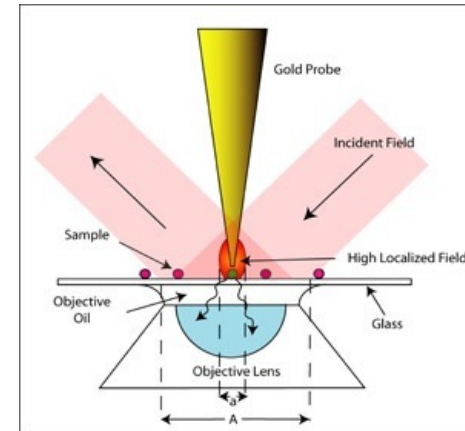

## Research topics

- Near-field propagation and diffraction
- Tip Probe near field distribution
- Near-field electromagnetic modeling
- Antenna design for near-field microscopy

K. Moon, et al., "Terahertz Near-Field Microscope: Analysis and Measurements of Scattering Signals", IEEE Trans. On Terahertz Science and Technology, vol. 1, no. 1, Sep. 2011, pp. 164-168



Graphene-based plasmonic antennas could enable a new generation of communications among nano devices in the Terahertz band (0.1-10 THz)<sup>1</sup>

## Plasmonic Multiphysics

- Graphene nanotechnology
- Nano-communications
- Nano-technology
- Plasmonic propagation
- Confined electromagnetic waves

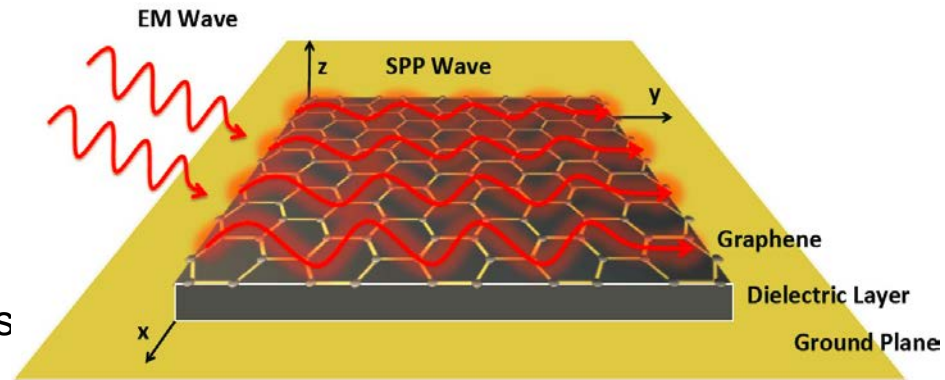
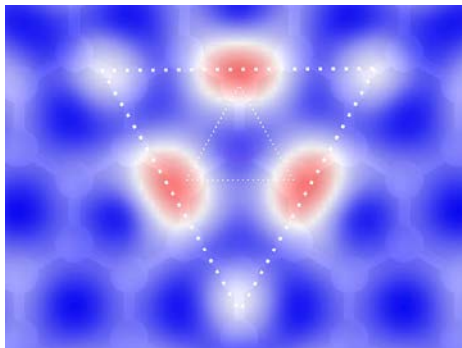

## Research topics

- Graphene electromagnetic characterization
- Nano-antenna parameters
- Surface plasmon polariton propagation at THz
- Plasmonic Antenna frequency response

[1] L. Zakrajsek, J. Jornet, et al, "Lithography Defined Plasmonic Graphene Antennas for Terahertz-Band Communications", IEEE Antennas and Wireless Propagation Letters, vol. 15, 2016, pp 1553-1556

*3D printing may allow the use of advanced nanoparticle materials to fabricate new miniature antenna able to approach the fundamental limits of electrical small antennas.*

## Fundamental limits of low-Q antennas

- Fundamental limits of small antennas
- Reactive vs radiative near-field energies
- 3D small antenna structures
- New antenna materials

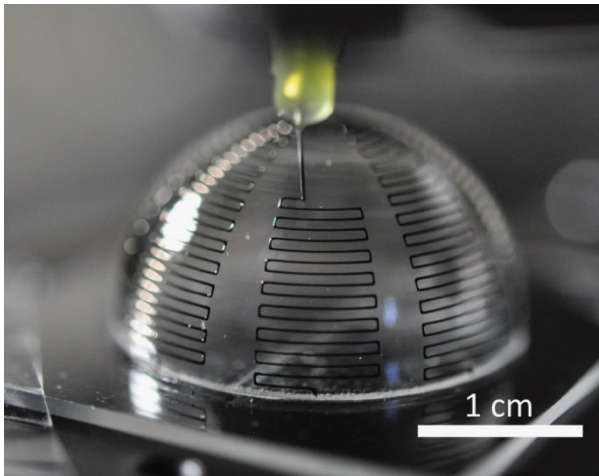

## Research topics

- Geometries for antenna miniaturization
- Electric and magnetic modal balance
- Design of new combination of geometries and materials for miniature antennas.

M. Lis, J. Lewis, et al., "Polymer Dielectrics for 3D-Printed RF Devices in the Ka Band", Advanced Materials Technologies, 2016



Lluís Jofre (IEEE S'79-M'83-SM'07-Fellow 2010) was born in Canet de Mar, Spain, in 1956. He received the M.Sc. (Ing) and Ph.D. (Doctor Ing.) degrees in electrical engineering (Telecom Eng.), from the Technical University of Catalonia (UPC), Barcelona, Spain, in 1978 and 1982, respectively. From 1981 to 1982, he was with the Ecole Supérieure d'Electricité,

Paris, France, where he was involved in microwave antenna design and imaging techniques for medical and industrial applications. Since 1982, he has been with the Communications Department, Telecommunication Engineering School, UPC, as a Full Professor since 1989. From 1986 to 1987, he was a Visiting Fulbright Scholar at the Georgia Institute of Technology, Atlanta, where he worked on antennas and electromagnetic imaging and visualization. From 1989 to 1994, he was the Director of the Telecommunication Engineering School, UPC, and from 1994 to 2000, he was the UPC Vice-Rector for Academic Planning. From 2000 to 2001, he was a Visiting Professor at the Electrical and Computer Engineering Department, Henry Samueli School of Engineering, University of California, Irvine. He has held different positions at institutional level: director of the Catalan Research Foundation (2002-04), director of the UPC-Telefonica Chair (2003 -2011), director of the Promoting Engineering Catalan Program EnginyCAT (2008-11) and general director for Catalan universities (2011-15).



Jordi Romeu (IEEE Fellow 2012) was born in Barcelona, Spain in 1962. He received the Ingeniero de Telecomunicación and Doctor Ingeniero de Telecomunicación, both from the Universitat Politècnica de Catalunya (UPC), Barcelona, Spain, in 1986 and 1991, respectively. Since 1985, he has been with the Electromagnetic and Photonic Engineering group, Signal Theory and Communications Department, UPC, where he is currently a Full Professor, working on the research of antenna near-field measurements, antenna diagnostics, and antenna design. He was Visiting Scholar at the Antenna Laboratory, University of California, Los Angeles, in 1999, under the North Atlantic Treaty Organization Scientific Program Scholarship and, in 2004, at University of California, Irvine. He is the holder of several patents and has published 50 refereed papers in international journals and 50 conference proceedings. Dr. Romeu was the Grand Winner of the European IT Prize, which was awarded by the European Commission, for his contributions in the development of fractal antennas in 1998.

## Antennas and Wireless Systems Lab:

L. Jofre, J. Romeu, J.M. Rius, A. Elias, S. Blanch, M.C. Santos